

High-Resolution 4.11M-Pixel Diagonal 6.75 mm (Type 1/2.7) Color CCD
for Consumer Digital Still Cameras Supports 30 frames/s VGA Moving Picture Imaging

ICX488DQ/DQF

The desires for higher resolution and further miniaturization are growing along with the increasingly widespread use of consumer digital still cameras.

To respond to these desires, Sony has now developed a new 4.11M-pixel diagonal 6.75 mm (Type 1/2.7) interlaced CCD, the ICX488DQ/DQF.

The ICX488DQ/DQF achieves both higher resolution and miniaturization by achieving the industry's smallest pixel size of 2.35 μm . Sony's unique horizontal and vertical pixel addition technology allows the ICX488DQ/DQF to provide both 4M-pixel class still picture and VGA moving picture imaging at 30 frames/s.

- ICX488DQ: Primary color filters, 24-pin DIP
ICX488DQF: Primary color filters, 24-pin SOP
- Diagonal 6.75 mm (Type 1/2.7) optical size and 4.11M effective pixels (2344H \times 1752V)
- The industry's smallest pixel size (2.35 μm unit pixel)
- 3-field readout method
- Supports 30 frames/s VGA moving picture imaging

The ICX488DQ/DQF is a diagonal 6.75 mm (Type 1/2.7) 4.11M-effective pixel CCD image sensor developed for use in high-resolution consumer digital still cameras. Used with a mechanical shutter, the ICX488DQ/DQF provides high-resolution image capture. Table 1 presents the pixel structure used in the ICX488DQ/DQF, and table 2 presents its imaging characteristics.

■ The Industry's Smallest Pixel Size

Figure 1 presents Sony's consumer digital still camera CCD lineup. Although the ICX488DQ/DQF corresponds to an increased pixel count version of Sony's earlier Type 1/2.7 3.24M-pixel ICX432DQ/DQF, Sony has developed the industry's smallest pixel (with a unit pixel size of 2.35 μm) by adopting the latest fine fabrication technologies, and thus succeeds in achieving both higher resolution and miniaturization at the same time. This allows the implementation of a 4M-pixel digital still camera from a design using the ICX432DQ/DQF without changing the optical system.

■ High Saturation Signal

To increase the dynamic range, the ICX488DQ/DQF adopts the same 3-field readout system used in the ICX432DQ/DQF. This readout mode allows finer design rules to be used in the vertical transfer block, which in turn allows the photodiode block to be made larger. The ICX488DQ/DQF achieves a saturation signal of 385 mV despite miniaturization to a 2.35 μm unit pixel size. (See table 2.)

■ VGA Moving Picture Imaging at 30 frames/s

Since the ICX488DQ/DQF adopts Sony's unique horizontal and vertical pixel addition technology, it can add together 4 pixels internally to the CCD itself and thus achieve a four times higher imaging sensitivity. In the 4/6-line readout mode (with horizontal addition), the ICX488DQ/DQF achieves both 30 frames/s high-speed imaging at high resolution (VGA: 640 \times 480 pixels). Thus the ICX488DQ/DQF achieves both high pixel count still picture and high-quality moving picture. It also features an extensive set of readout modes, including 2/6-line readout mode that allows high-speed shutter operation, and partial scan modes designed for even higher speed AF control.

■ System IC

Sony also provides the CXD3629GA driver timing generator IC that includes built-in horizontal and vertical drivers. In addition to a VGA equivalent moving picture mode, this IC also supports high frame rate readout mode and AF mode as well.

V O I C E

We developed this 4M-pixel Type 1/2.7 CCD that achieves both a high pixel count still picture and high-quality moving picture at the same time, and also achieves further miniaturization. To respond to market needs for miniaturization and higher pixel counts, we took maximum advantage of Sony's fine fabrication technologies and achieved the industry's smallest pixel size. I strongly recommend that you consider developing new products based on this device, which combines both the latest technologies and functions.

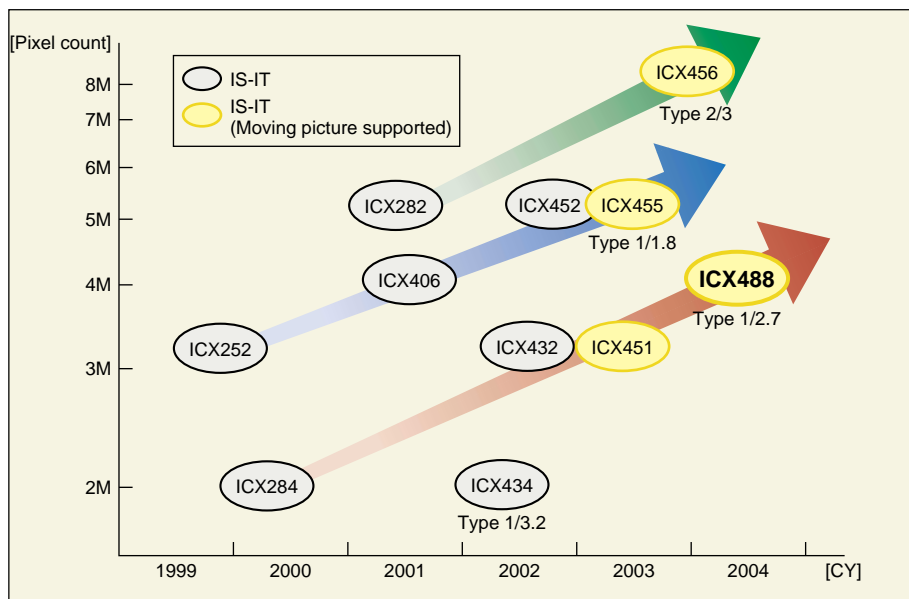

■ Figure 1 Consumer Digital Still Camera CCD Lineup

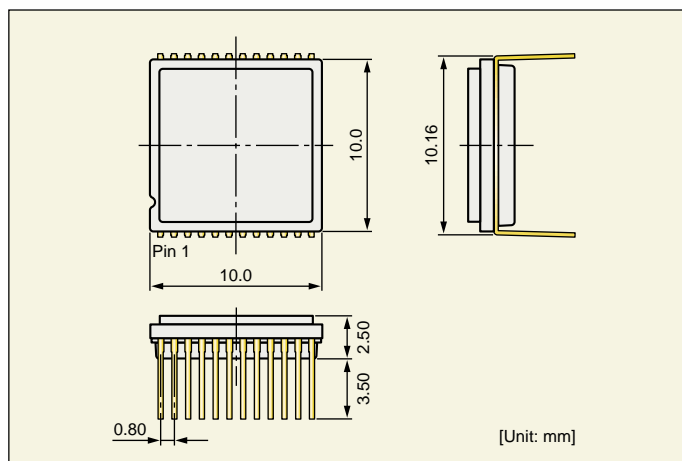

■ Figure 2 Package Dimensions (DIP)

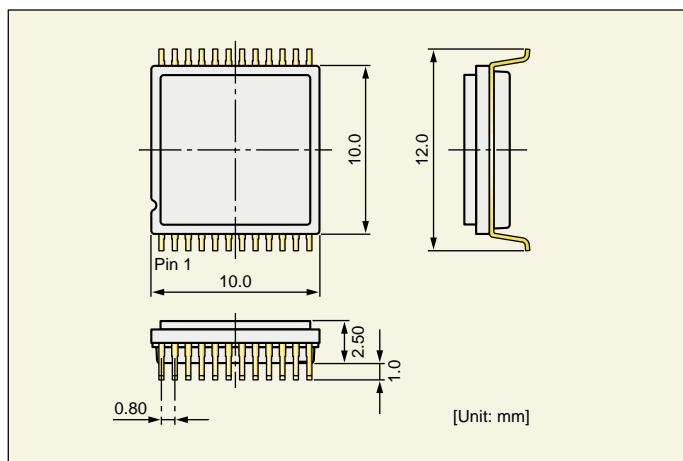

■ Figure 3 Package Dimensions (SOP)

■ Table 1 Device Structure

Item	ICX488DQ/DQF
Image size	Diagonal 6.75 mm (Type 1/2.7)
Transfer method	Frame readout interline transfer method
Readout method	3-field readout
Total number of pixels	Approx. 4.23M (2396H × 1766V)
Number of effective pixels	Approx. 4.11M (2344H × 1752V)
Number of active pixels	Approx. 3.95M (2304H × 1716V)
Number of recommended recording pixels (Aspect ratio: 4:3)	Approx. 3.87M (2272H × 1704V)
Unit cell size	2.35 μm (H) × 2.35 μm (V)
Horizontal drive frequency	27 MHz
Package	24-pin plastic DIP/SOP

■ Table 2 Image Sensor Characteristics

Item	ICX488DQ/DQF	Remarks	
Sensitivity (G signal)	160mV	3200 K, 706 cd/m ² , 1/30 s accumulation, F5.6	
Saturation signal	Frame readout mode	385mV	
Smear (F5.6)	Frame readout mode	-83.0dB	
	4/6-line readout mode*	-78.5dB	
	4/12-line readout mode*	-72.5dB	
Frame rate	Frame readout mode	4.28 frames/s	
	4/6-line readout mode*	30 frames/s	Number of output lines: 584
	4/12-line readout mode*	60 frames/s	Number of output lines: 292

*: With horizontal addition

Note: This device was designed for use in consumer digital still cameras and may not be appropriate for other applications. Contact your Sony representative for consultation when considering this product for use on other applications.